

# FITTING INSTRUCTIONS



These instructions relate to a left-hand hinged Hasp. To adapt this lock to a right-hand hinged Hasp, see notes under Diagram C overleaf.

**Preparation:** Before installing this D&D HaspLock™, ensure:

- the maximum gap between the two fixing frames is no more than 5/8" (16mm).
- the Hasp component has at least 2" (50mm) clearance below the lock assembly so the hasp hangs vertically when open. See Diagram D.

**Tools required:** Electric or cordless drill, 9/32" (7mm) drill-bit, Phillips No. 2 screwdriver (hand & powered types), square, level, pencil.

1. Mark a fine, level centerline (pencil) across the face of the two frames, as shown at right. Use the square to mark this centerline around to the inside of both frames, and across the two frames at the rear.
2. Fold the drilling template at the heavy dotted lines. Ensure the 'Lock Side' of the template is positioned on the door frame (see Diagram B overleaf). Line up the template 'Centerline' with the marked centerline, and align the 'Vertical Door Line' with the edge of

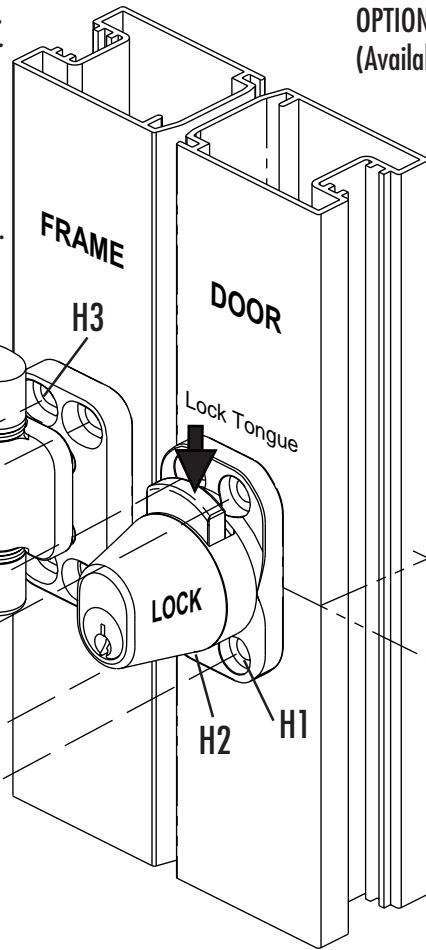
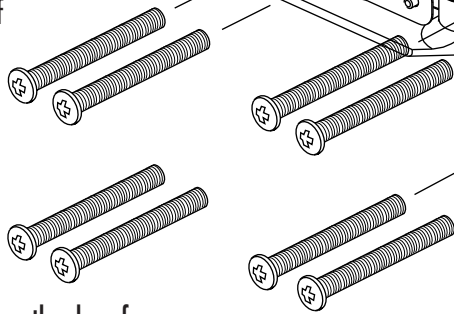

OPTIONAL BLIND COVER  
(Available separately)

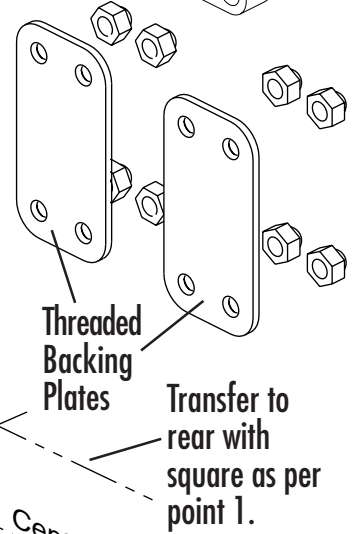

Threaded Backing Plates  
Transfer to rear with square as per point 1.

DIAGRAM A

continued overleaf...

## DRILLING TEMPLATE

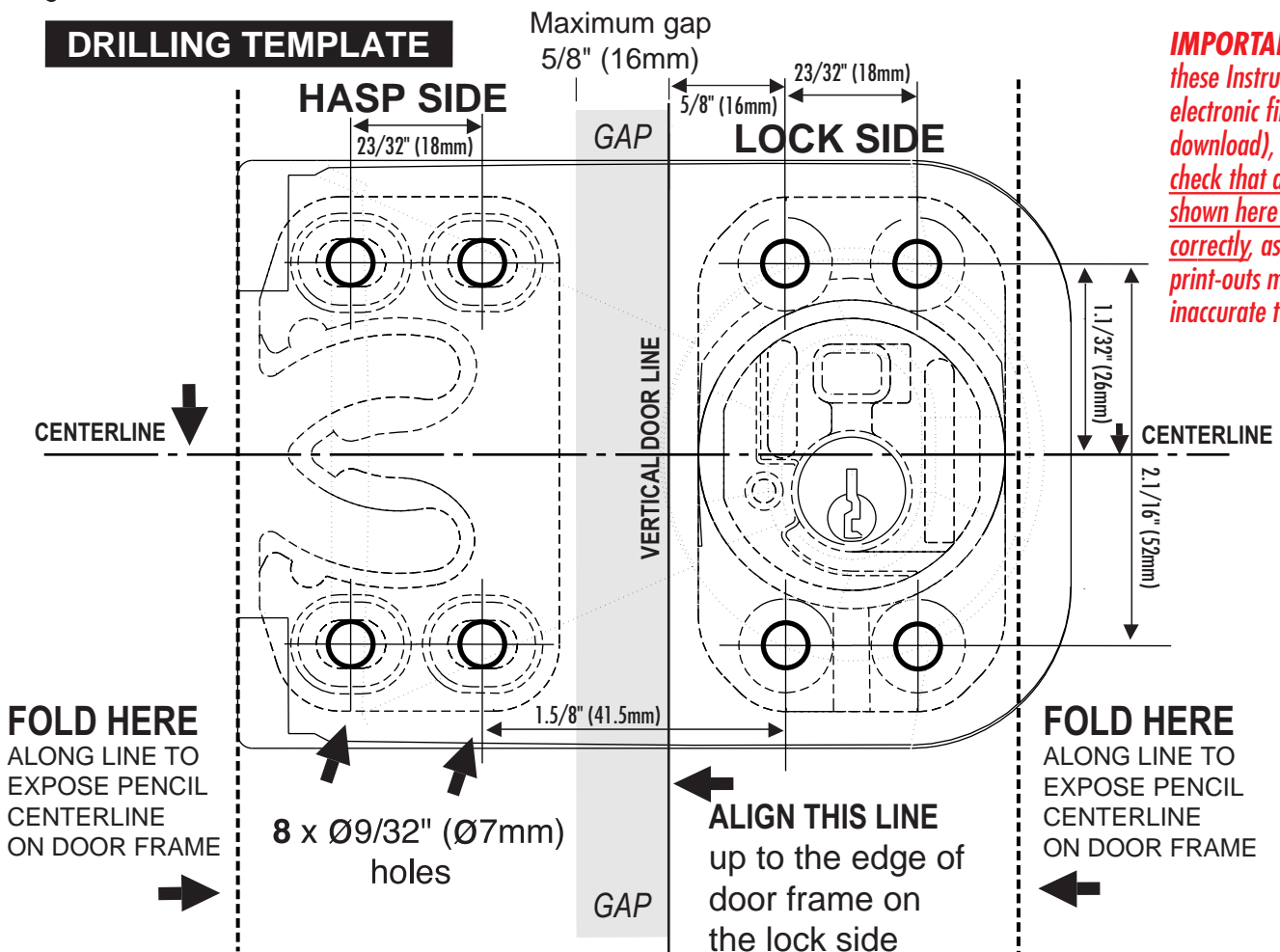

**IMPORTANT:** If printing these Instructions from an electronic file (e.g. website download), be sure to check that dimensions shown here measure correctly, as differences in print-outs may result in inaccurate template holes.

**FOLD HERE**  
ALONG LINE TO EXPOSE PENCIL CENTERLINE ON DOOR FRAME

8 x Ø9/32" (Ø7mm) holes

**ALIGN THIS LINE**  
up to the edge of door frame on the lock side

**FOLD HERE**  
ALONG LINE TO EXPOSE PENCIL CENTERLINE ON DOOR FRAME

## FITTING INSTRUCTIONS CONTINUED...

the door frame, as shown. Mark the centerpoints in eight places using a sharp object.

3. Remove the drilling template, and, moving to the rear of the 'Door' and 'Frame', re-position it upside-down using the same alignment procedure as described for the front. This ensures accurate, level drilling through the sections.
4. Drill Ø9/32" (Ø7mm) holes fully through the frame in eight places from both sides. (Smaller pilot holes may assist drilling accuracy.)
5. To attain the correct length of screw to fit your door and frame depth, insert one of the screws supplied through hole 'H1' of the Lock. Position the Lock, with screw, firmly against the door frame with the screw protruding from rear. Mark and then cut the screw to attain a maximum of 5/16" (8mm) of thread protruding from the rear face. Cut all remaining screws to the same length.
6. To begin securing the HaspLock as shown in 'Diagram A' (ensure the Lock Tongue is facing upwards) insert screws through holes 'H1' and 'H2'. Position a Threaded Backing Plate over the screws and secure loosely.
7. Insert the key into the Lock and rotate clockwise to retract the Lock Tongue. With the tongue retracted, insert the two top screws through the Lock and fasten through the threaded plate. Tighten all four screws securely and then fasten four of the dome-nuts supplied. The Lock is now installed.
8. To install the Hasp, take another screw and place it through the slotted hole 'H3'. For ease of insertion, place this screw through the hole before placing Hasp against the Frame. With the screw in place, position the Hasp up to the Frame. Install the second Backing Plate and secure loosely. Now install the remaining three screws into the backing plate, tightening them just enough so that all screws can move within the adjustment slots.
9. To attain the final position, flip the Hasp over the Lock, insert the key and rotate clockwise to allow full hasp locking. Move the Hasp so that it is centered over the Lock. Adjust as required to attain equal clearances around the Lock. At the base of the hinging plate, mark around the plate with a pencil to indicate the final location.
10. Unlock the Hasp and remove the key. While ensuring that hinge plate is correctly located around the pencil marks, tighten the screws one by one. When alignment is complete, secure all screws firmly and then fit all remaining dome-nuts.

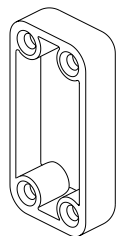
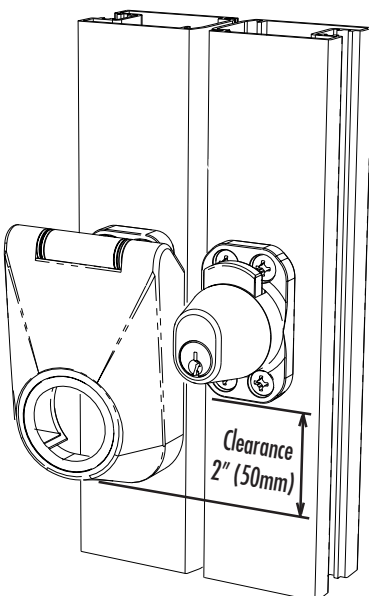
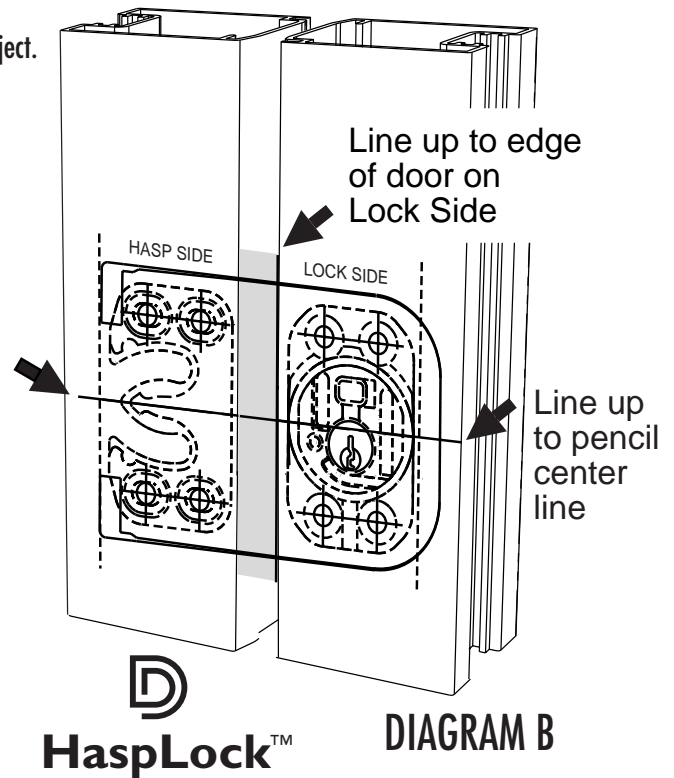

**OPTIONAL BLIND COVER**  
The optional blind cover provides added security and better aesthetics. Available from your supplier.

### LEFT- OR RIGHT-HAND HINGED HASP?

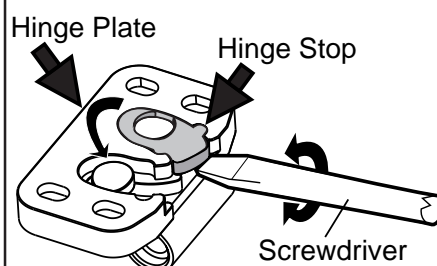

The D&D HaspLock™ can be reversed to become a right-hand hinged hasp by extracting the black Hinge Stop and inserting it in the opposite slot within the Hinge Plate.

DIAGRAM C

### REPLACE THE LOCK CYLINDER?

To re-key or upgrade to a higher security lock cylinder...

1. Remove screw from back plate.
2. Place lock body as shown, allowing at least 3/16" (4mm) clearance under the lock to allow the back plate to eject.
3. Tap lightly on the face of the cylinder with an OD5/8" (16mm) max. plastic punch or similar soft punch.

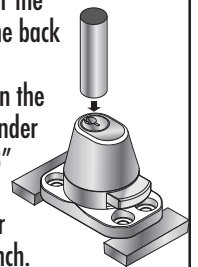

**MAINTENANCE:** Lubricate the D&D HaspLock using only graphite powder. DO NOT use oil or grease.

**WARRANTY & LIMITATION OF LIABILITY:** The products are warranted to be free of defects in materials and workmanship to the original purchaser for as long as he/she owns the product. If a defect appears, the original purchaser may return the item, freight prepaid, together with proof of purchase to the company or its approved international agents. The company or agent will, at its discretion, repair or replace the defective item or part without charge to the purchaser. THIS WARRANTY SHALL NOT APPLY WHEN the product has been tampered with, when repairs or attempted repairs have been made by unauthorised persons, where the item has been subjected to misuse, abuse, accident or damage in transit, or where the installer has not followed the instructions set out during installation or operations. No charges will be accepted for unauthorised parts, repairs or services. IN NO EVENT SHALL THE COMPANY BE LIABLE FOR ANY INCIDENTAL OR CONSEQUENTIAL DAMAGES. No warranty is given other than that set out above. No express or implied warranties (including statutory warranties) apply, other than warranties which may not legally be excluded.



D&D Technologies

AUSTRALIA: Unit 6, 4-6 Aquatic Dr, Frenchs Forest NSW 2086  
USA: 7731 Woodwind Drive, Huntington Beach, CA 92647